

T-SERIES Mid-size Outdoor



T29
 4000 BTU/Hr.
 1173 Watts



T43
 6000, 8000, 10000 BTU/Hr.
 1758, 2344, 2930 Watts



T50
 12000 BTU/Hr.
 3516 Watts



T53
 19000 BTU/Hr.
 5567 Watts

Industry Standards

UL/cUL Listed; Type 12, 3R, 4; 4X optional; File No. SA6453
 UR/cUR Recognized

UR/cUR Recognized on select models, reference performance data tables.

CE
 GOST
 Telcordia GR-487 capable

Application

- Industrial automation
- Telecommunications equipment
- Package handling equipment
- Security and defense systems
- And more

Features

- Stock models equipped with head pressure control for low-ambient operation, compressor heater, coated condenser coil, malfunction switch, thermostat and heater package
- R134A or R-407C earth-friendly refrigerant
- Models for 115, 230 and 460 VAC power input
- UL Listed to save customers time and money with agency approvals (some models UL recognized)
- Outdoor model operating temperature range from -40 F/-40 C to 131 F/55 C
- Exterior and fully recessed mounting options on many models
- Compact footprint to minimize real estate and maximize capacity
- Reliable mechanical thermostat on enclosure side of the unit
- Dual condenser-side air movers for performance redundancy
- Painted galvanized sheet-metal cover for rugged factory and outdoor environments
- Easy-mount flanges for simple installation

- Cleanable, reusable aluminum mesh filter protects coils for maximum cooling performance
- Mounting hardware, gaskets and user manual furnished with the unit
- Every unit functionally tested before shipping
- Standard Outdoor Air Conditioner models also include:
 - Telcordia GR-487 capable
 - Thermostat
 - Corrosion-resistant components
 - Malfunction switch
 - Compressor heater
 - Head pressure control
 - Enclosure heater

Finish

- RAL 7035 light-gray, semi-textured powder-coat paint
- Other colors and textures available

Accessories

Visit www.McLeanCoolingTech.com to download 2D and 3D CAD drawings into the overall design of your electronic system.

Options

- Thermostat Malfunction Package
- Special Voltage Package
- Outdoor Package
- Harsh Environment Package*
- Stainless Steel Package*
- Heater Package
 - * PROAIR Harsh Environment air conditioner may be more appropriate. Refer to PROAIR Harsh Environment air conditioner catalog section. Consult the Factory for availability and catalog number.

Air Conditioners
Performance Data T29 4000 BTU/Hr. (1173 Watt) Models

CATALOG NUMBER			
Outdoor Model without Heat Pkg.	T290416G100	T290426G100	T290446G400
Outdoor Model with Heat Pkg.	T290416G150	T290426G150	—
Outdoor Model/SST/Corrosion/4X	T290416G159	T290426G161	—
Outdoor Model/SST/Corrosion/4X/Heater	T290416G156	T290426G160	T290446G403
COOLING PERFORMANCE			
Nominal:			
BTU/Hr.	3600/4000	3600/4000	3600/4000
Watts	1055/1172	1055/1172	1055/1172
At 131 F/131 F (55 C/55 C):			
BTU/Hr. (50/60 Hz)	3950/4250	3950/4250	3950/4250
W (50/60 Hz)	1157/1245	1157/1245	1157/1245
At 95 F/95 F (35 C/35 C):			
BTU/Hr. (50 /60 Hz)	3500/3900	3500/3900	3500/3900
W (50/60 Hz)	1025/1143	1025/1143	1025/1143
Refrigerant	R-134A	R-134A	R-134A
Refrigerant Charge (ounces/grams)	14.3/404	14.3/404	14.3/404
Operating Temperature Range:			
Maximum (°F/°C)	131/55	131/55	131/55
Minimum (°F/°C)	-40/-40	-40/-40	-40/-40
Airflow at 0 Static Pressure:			
Internal loop 50 Hz (CFM / m ³ /hr.)	172/292	172/292	172/292
External loop 50 Hz (CFM / m ³ /hr.)	195/331	195/331	195/331
Internal loop 60 Hz (CFM / m ³ /hr.)	205/348	205/348	205/348
External loop 60 Hz (CFM / m ³ /hr.)	235/399	235/399	235/399
Max. Heater W (Outdoor Models)	1000	1000	
ELECTRICAL DATA			
Rated Voltage	115	230	460V 1PH
Frequency (Hz)	50/60	50/60	50/60
Operating Range	+/- 10%	+/- 10%	+/- 10%
Max. Power Consumption (W at 50/60 Hz)	1587/1564	1587/1564	1748
Max. Nominal Current (A at 50/60 Hz)	13.8/13.6	6.9/6.8	3.8
Starting Current (I)	48	23	12
Agency Approvals		cUL Listed CE GOST	cUR Recognized CE GOST
Others available upon request			
Power Input Description	6-ft. cord with NEMA 5-20 plug	6-ft. cord with NEMA 6-15 plug	6-ft. cord with wire leads
ENCLOSURE PROTECTION			
UL Type	Type 12, 3R, 4 standard Type 4X Stainless steel optional		
CONTROLLER			
Description	Basic mechanical thermostat		
Thermostat Location	Enclosure side on all base models		
Factory Thermostat Setting (°F/°C)	80/27		
SOUND LEVEL			
At 1.5 Meters	67 dB(A)		
UNIT CONSTRUCTION			
Material	Galvanized sheet metal standard Stainless steel optional		
Finish	RAL 7035 light-gray, semi-textured powder-coat paint standard		
UNIT DIMENSIONS			
Height (in./mm)	29/737		29/737
Width (in./mm)	17/432		17/432
Depth (in./mm)	11.3/287		11.3/287
Weight (lb./kg)	107/48.6		127/58

Sealed Enclosure Cooling

Performance Curves for T29 Models 4000 BTU/Hr. (1173 Watt)

T29-04x6-Gxxx Capacity Curves 50 Hz

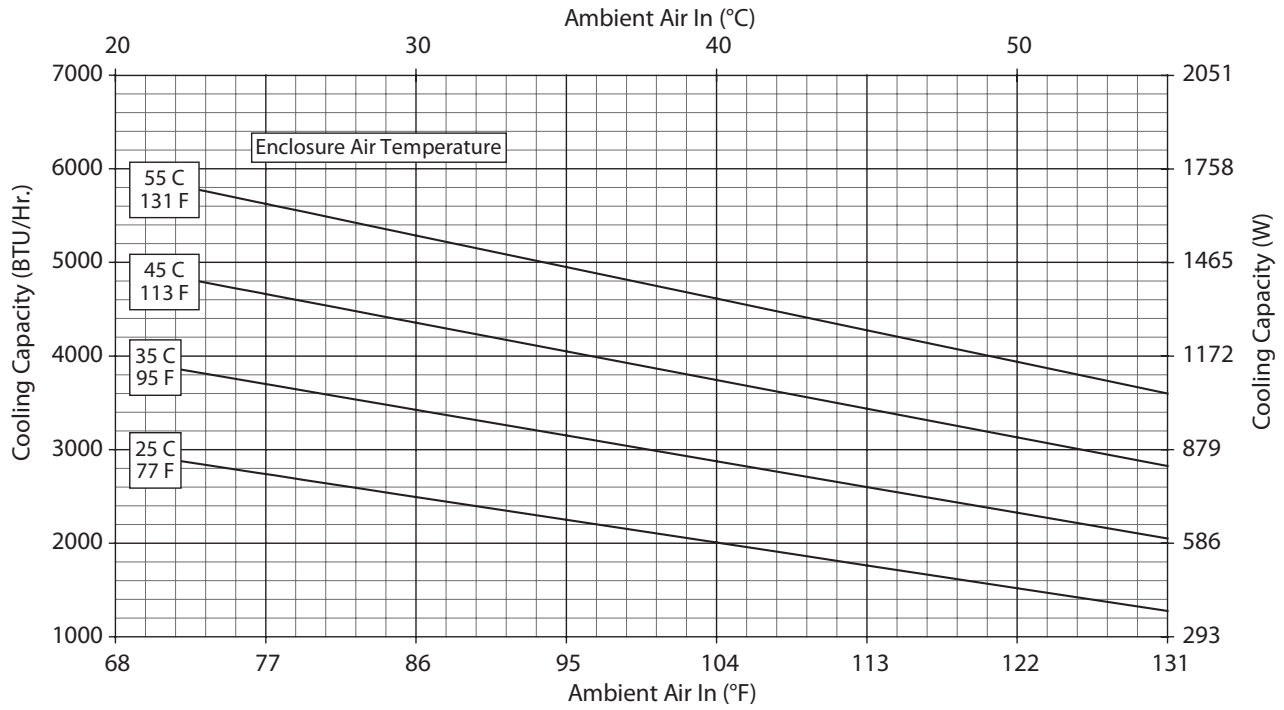

T29-04x6-Gxx Capacity Curves 60 Hz

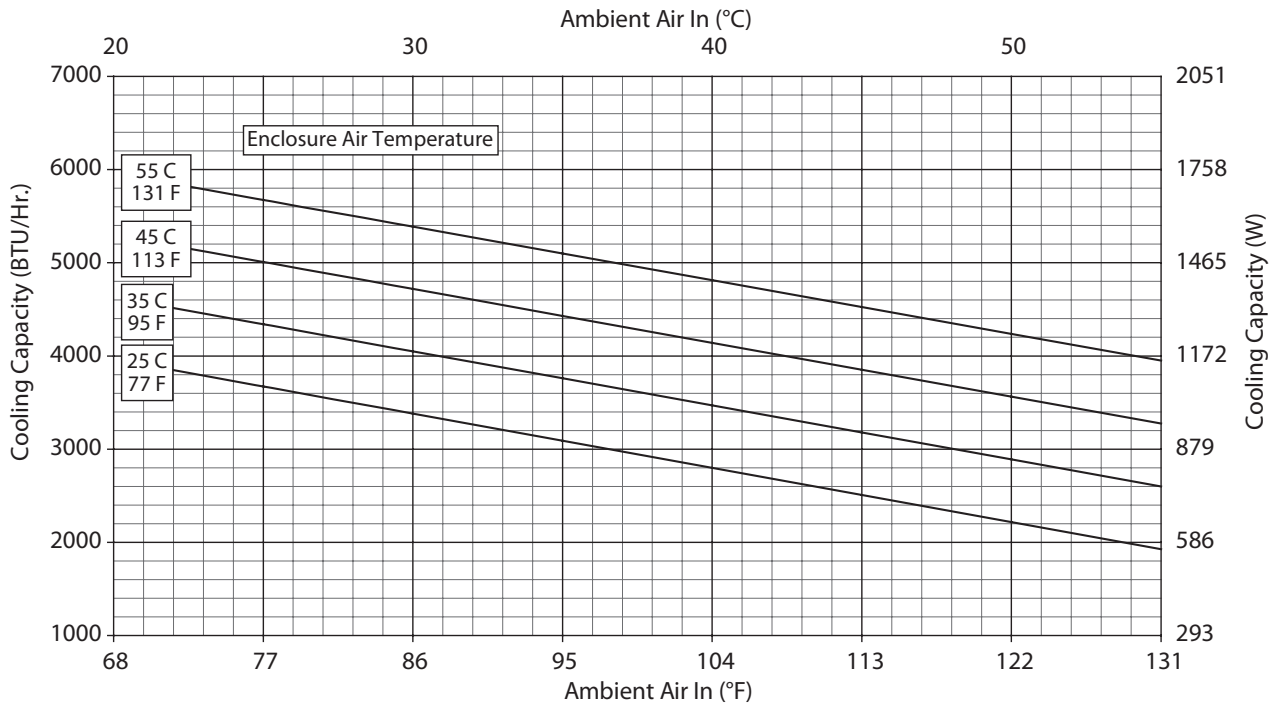

Air Conditioners

T29 Models 4000 BTU/Hr. (1173 Watt)

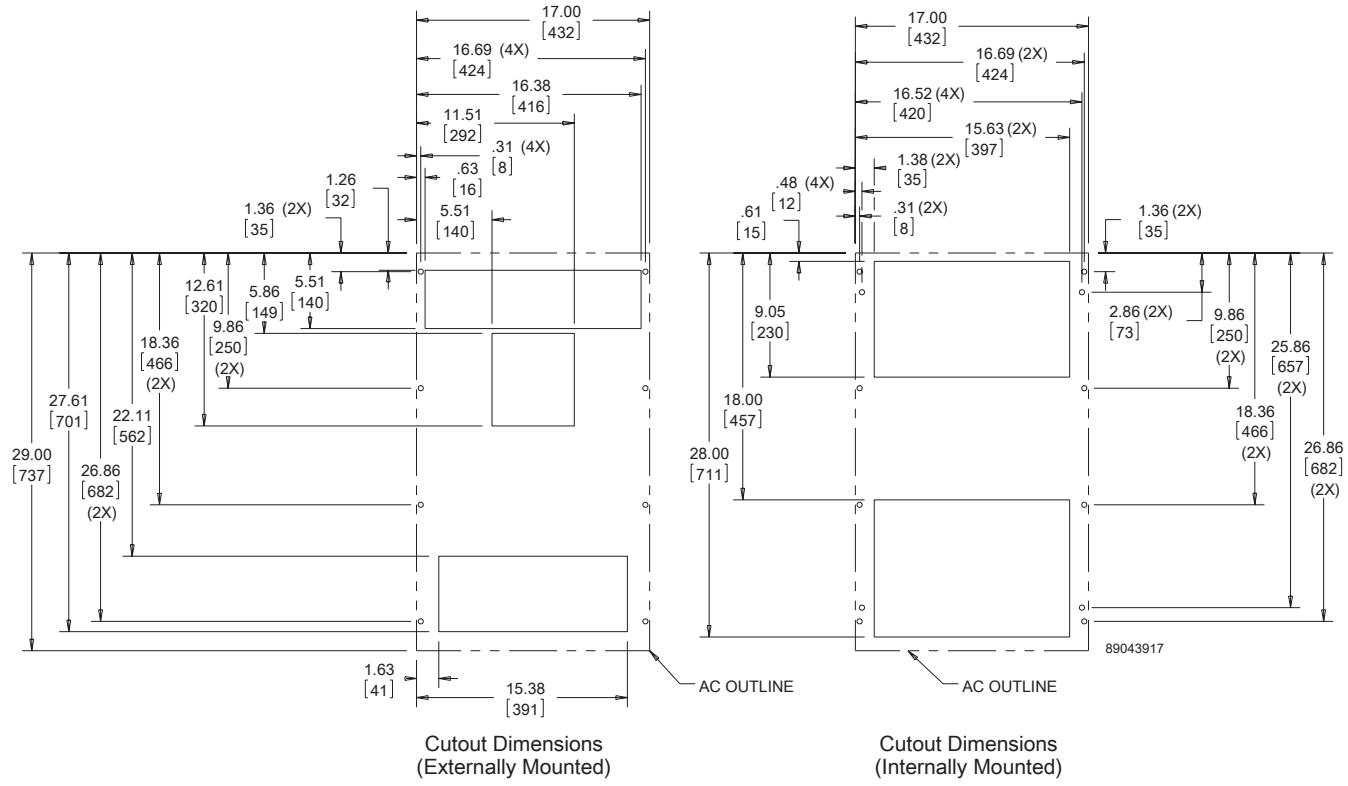
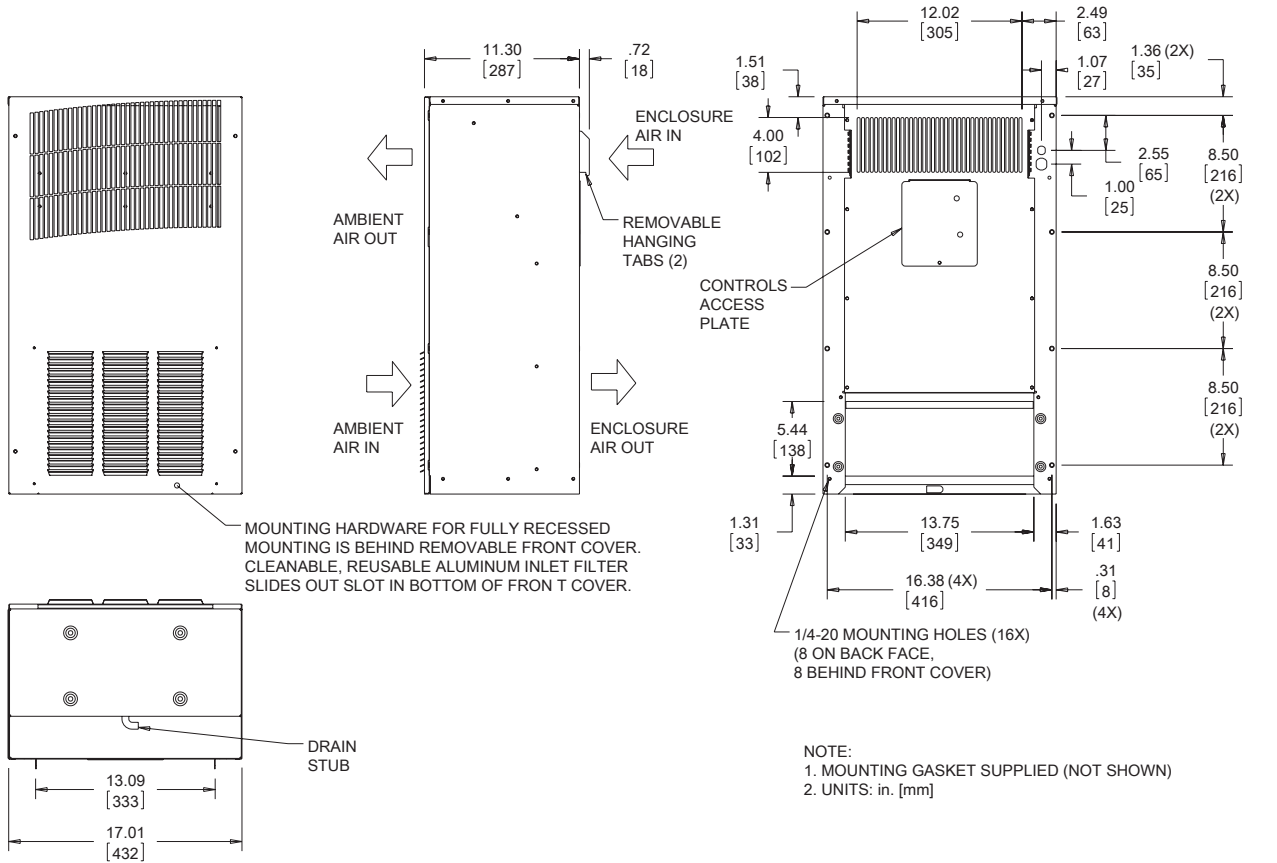

Visit www.McLeanCoolingTech.com to download 2D and 3D CAD drawings into the overall design of your electronic system.

Performance Data **T43 6000 BTU/Hr. (1758 Watt) Models**

CATALOG NUMBER			
Outdoor Model without Heat Pkg.	T430616G100	T430626G100	T430646G400
Outdoor Model with Heat Pkg.	T430616G150	T430626G150	T430646G153
Outdoor Model/SST/Corrosion/4X	T430616G102	T430626G159	—
Outdoor Model/SST/Corrosion/4X/Heater	—	—	—
COOLING PERFORMANCE			
Nominal:			
BTU/Hr.	6310/6680	6520/6770	6520/6770
Watts	1848/1958	1910/1985	1910/1985
At 131 F/131 F (55 C/55 C):			
BTU/Hr. (50/60 Hz)	6400/6680	6520/6774	6520/6774
W (50/60 Hz)	1875/1957	1910/1985	1910/1985
At 95 F/95 F (35 C/35 C):			
BTU/Hr. (50 /60 Hz)	5500/5900	5461/5846	5461/5846
W (50/60 Hz)	1611/1729	1600/1713	1600/1713
Refrigerant	R-134A	R-134A	R-134A
Refrigerant Charge (ounces/grams)	30/850	30/850	30/850
Operating Temperature Range:			
Maximum (°F/°C)	131/55	131/55	131/55
Minimum (°F/°C)	-40/-40	-40/-40	-40/-40
Airflow at 0 Static Pressure:			
Internal loop 50 Hz (CFM / m ³ /hr.)	310/527	310/527	310/527
External loop 50 Hz (CFM / m ³ /hr.)	345/586	345/586	345/586
Internal loop 60 Hz (CFM / m ³ /hr.)	320/544	320/544	320/544
External loop 60 Hz (CFM / m ³ /hr.)	355/603	355/603	355/603
Max. Heater W (Outdoor Models)	1000	1000	N/A
ELECTRICAL DATA			
Rated Voltage	115	230	460V 1PH
Frequency (Hz)	50/60	50/60	50/60
Operating Range	+/- 10%	+/- 10%	+/- 10%
Max. Power Consumption (W at 50/60 Hz)	1058/989	1012/874	1104/966
Max. Nominal Current (A at 50/60 Hz)	9.2/8.6	4.4/3.8	2.4/2.1
Starting Current (A)	57.2	27	14
Agency Approvals	cUL Listed CE GOST	Others available upon request	cUR Recognized CE GOST
Power Input Description	6-ft. cord with NEMA 5-20 plug	6-ft. cord with NEMA 6-15 plug	6-ft. cord with wire leads
ENCLOSURE PROTECTION			
UL Type	Type 12, 3R, 4 standard Type 4X Stainless steel optional		
International Rating	IP56 on the internal loop; IP34 on the external loop		
CONTROLLER			
Description	Basic mechanical thermostat		
Thermostat Location	Enclosure side on all base models		
Factory Thermostat Setting (°F/°C)	80/27		
SOUND LEVEL			
At 1.5 Meters	65.7 dB(A)		
UNIT CONSTRUCTION			
Material	Galvanized sheet metal standard Stainless steel optional		
Finish	RAL 7035 light-gray, semi-textured powder-coat paint standard		
UNIT DIMENSIONS			
Height (in./mm)	43/1092		
Width (in./mm)	15.75/400		
Depth (in./mm)	10.9/279		
Weight (lb./kg)	125/57		

Air Conditioners

Performance Curves for T43 Models 6000 BTU/Hr. (1758 Watt)

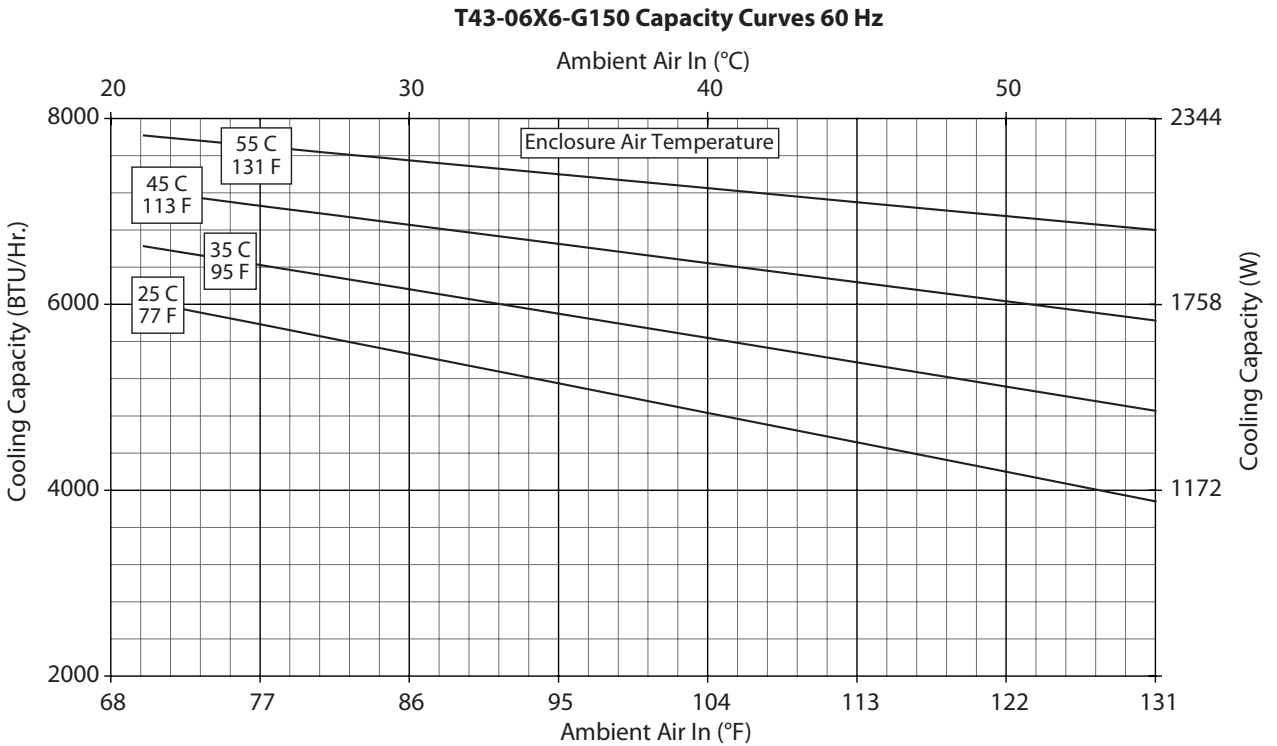
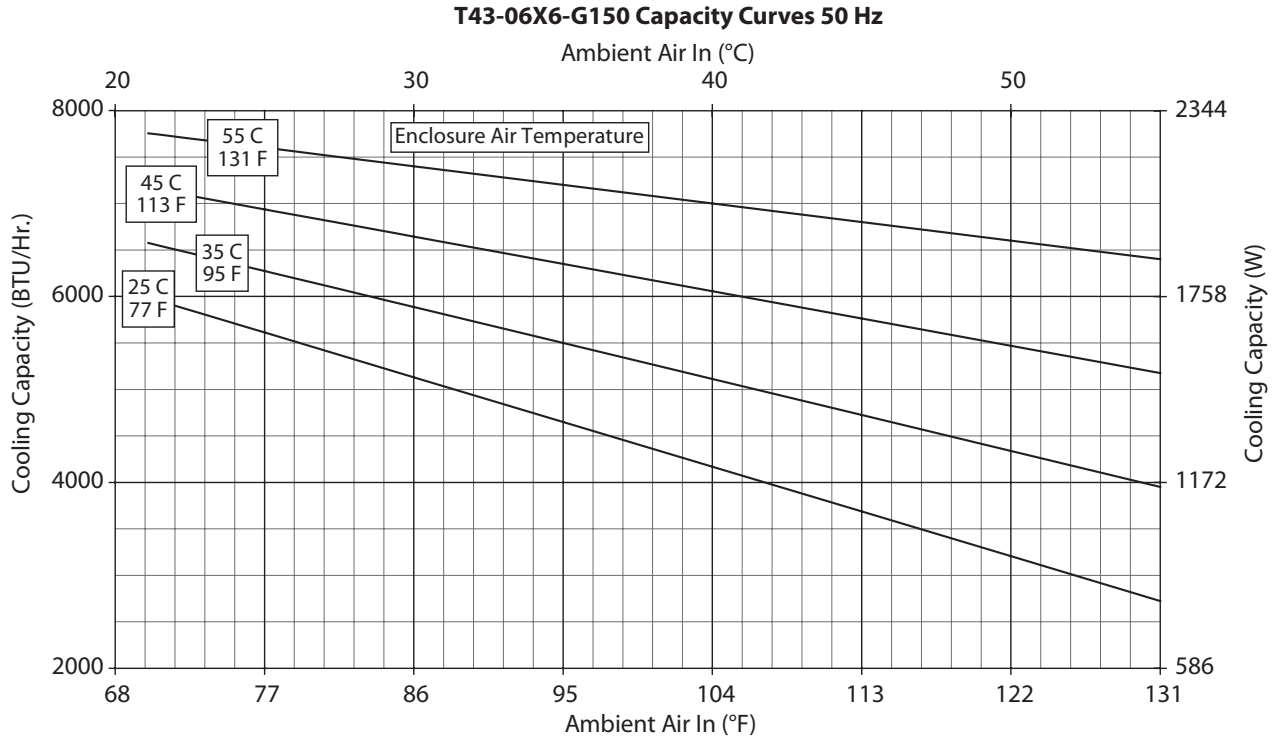

Sealed Enclosure Cooling

Performance Data **T43 8000 BTU/Hr. (2344 Watt) Models**

CATALOG NUMBER			
Outdoor Model without Heat Pkg.	T430816G100	T430826G100	T430846G400
Outdoor Model with Heat Pkg.	T430816G150	T430826G150	T430846G403
Outdoor Model/SST/Corrosion/4X	T430816G153	T430826G108	T430846G402
Outdoor Model/SST/Corrosion/4X/Heater	—	—	—
COOLING PERFORMANCE			
Nominal:			
BTU/Hr.	7900/8600	7400/8200	7400/8200
Watts	2310/2500	2160/2400	2160/2400
At 131 F/131 F (55 C/55 C):			
BTU/Hr. (50/60 Hz)	7937/8629	7484/8215	7484/8215
W (50/60 Hz)	2326/2528	2193/2407	2193/2407
At 95 F/95 F (35 C/35 C):			
BTU/Hr. (50 /60 Hz)	6401/7100	5940/6705	5940/6705
W (50/60 Hz)	1875/2080	1740/1965	1740/1965
Refrigerant	R-134A	R-134A	R-134A
Refrigerant Charge (ounces/grams)	36/1022	36/1022	36/1022
Operating Temperature Range:			
Maximum (°F/°C)	131/55	131/55	131/55
Minimum (°F/°C)	-40/-40	-40/-40	-40/-40
Airflow at 0 Static Pressure:			
Internal loop 50 Hz (CFM / m ³ /hr.)	273/464	273/464	273/464
External loop 50 Hz (CFM / m ³ /hr.)	310/527	310/527	310/527
Internal loop 60 Hz (CFM / m ³ /hr.)	290/493	290/493	290/493
External loop 60 Hz (CFM / m ³ /hr.)	315/535	315/535	315/535
Max. Heater W (Outdoor Models)	1000	1000	N/A
ELECTRICAL DATA			
Rated Voltage	115	230	460V 1PH
Frequency (Hz)	50/60	50/60	50/60
Operating Range	+/- 10%	+/- 10%	+/- 10%
Max. Power Consumption (W at 50/60 Hz)	1196/1288	1196/1242	1334/1380
Max. Nominal Current (A at 50/60 Hz)	10.4/11.2	5.2/5.4	2.9/3.0
Starting Current (A)	48.3	27	14
Agency Approvals	cUL Listed CE GOST		cUR Recognized CE GOST
Others available upon request			
Power Input Description	6-ft. cord with NEMA 5-20 plug	6-ft. cord with NEMA 6-15 plug	6-ft. cord with wire leads
ENCLOSURE PROTECTION			
UL Type	Type 12, 3R, 4 standard Type 4X Stainless steel optional		
International Rating	IP56 on the internal loop; IP34 on the external loop		
CONTROLLER			
Description	Basic mechanical thermostat		
Thermostat Location	Enclosure side on all base models		
Factory Thermostat Setting (°F/°C)	80/27		
SOUND LEVEL			
At 1.5 Meters	65.7 dB(A)		
UNIT CONSTRUCTION			
Material	Galvanized sheet metal standard Stainless steel optional		
Finish	RAL 7035 light-gray, semi-textured powder-coat paint standard		
UNIT DIMENSIONS			
Height (in./mm)	43/1092		
Width (in./mm)	15.75/400		
Depth (in./mm)	10.9/279		
Weight (lb./kg)	125/57		

Sealed Enclosure Cooling

Air Conditioners

Performance Curves for T43 Models 8000 BTU/Hr. (2344 Watt)

T43-08X6-G150 Capacity Curves 50 Hz

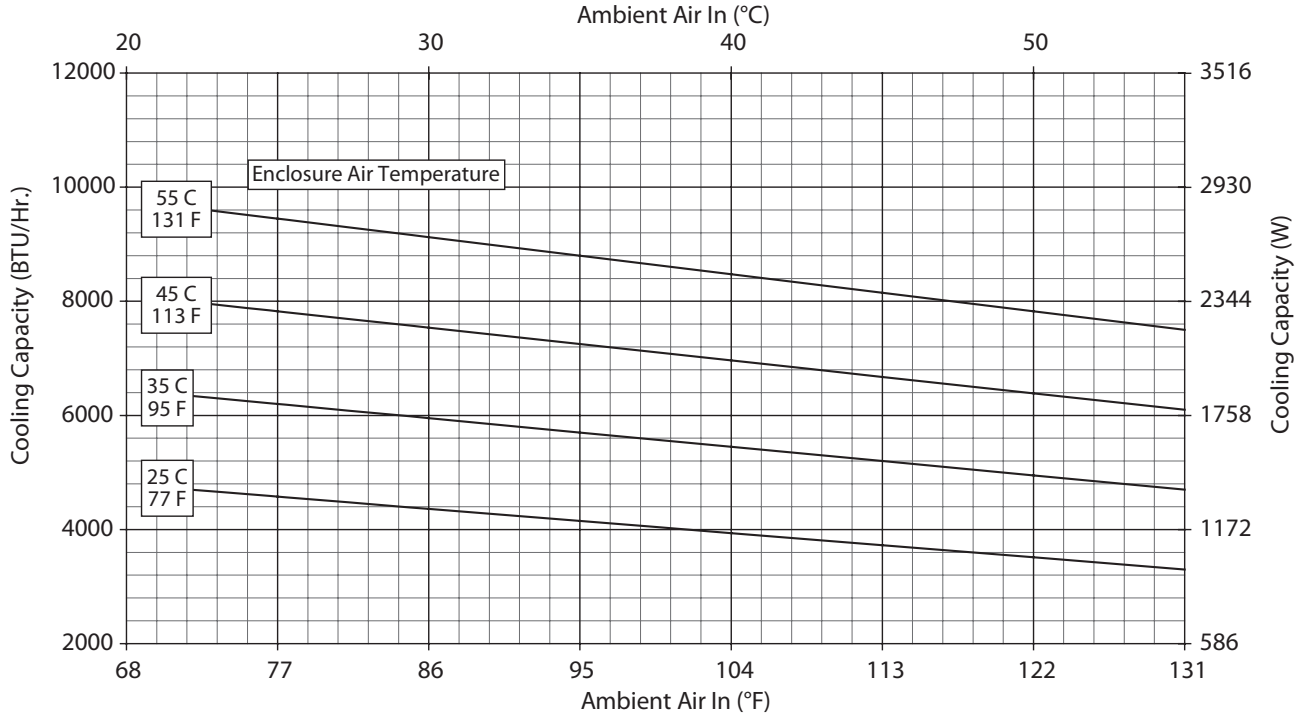

T43-08X6-G150 Capacity Curves 60 Hz

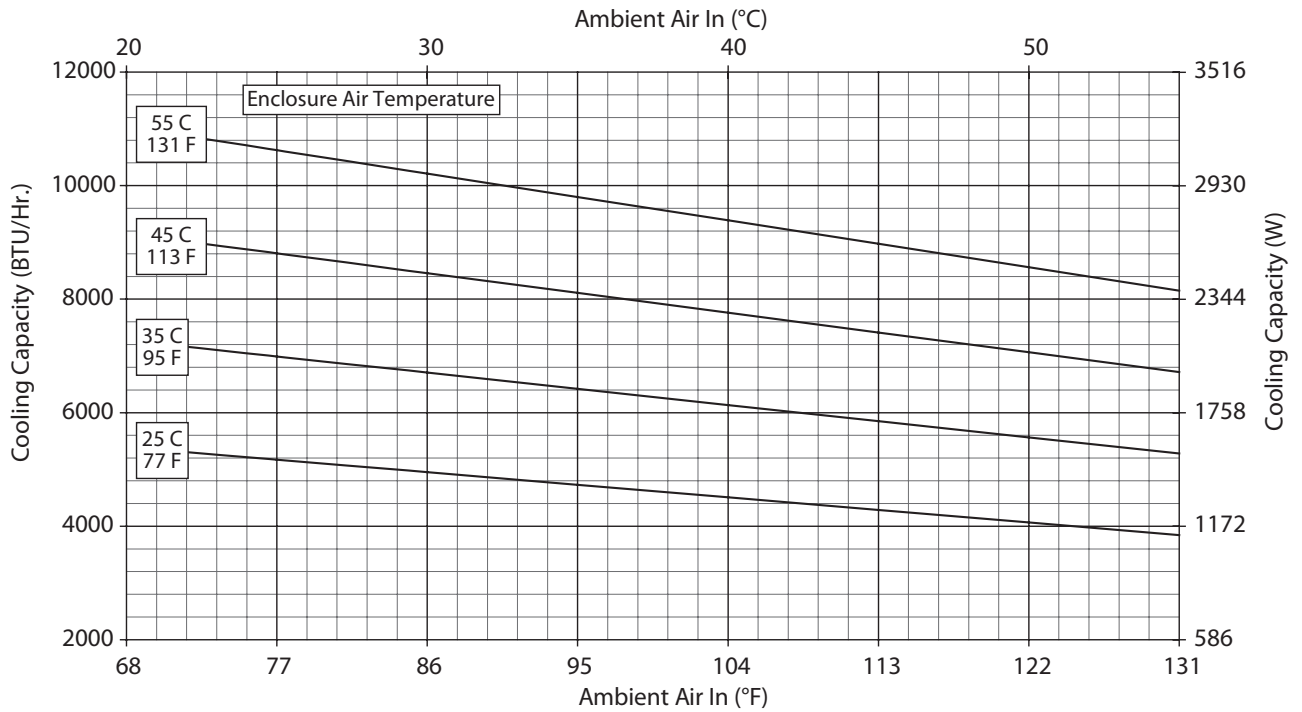

Sealed Enclosure Cooling

Performance Data **T43 10000 BTU/Hr. (2930 Watt) Models**

CATALOG NUMBER			
Outdoor Model without Heat Pkg.	T431016G100	T431026G100	T431046G400
Outdoor Model with Heat Pkg.	T431016G150	T431026G150	—
Outdoor Model/SST/Corrosion/4X	T431016G102	T431026G104	T431046G406
Outdoor Model/SST/Corrosion/4X/Heater	T431016G153	T431026G152	—
COOLING PERFORMANCE			
Nominal:			
BTU/Hr.	9670/10300	10100/10500	10100/10500
Watts	2831/3016	2957/3075	2957/3075
At 131 F/131 F (55 C/55 C):			
BTU/Hr. (50/60 Hz)	9667/10290	10039/10669	10039/10669
W (50/60 Hz)	2832/3015	2941/3126	2941/3126
At 95 F/95 F (35 C/35 C):			
BTU/Hr. (50/60 Hz)	7663/8397	8458/8837	8458/8837
W (50/60 Hz)	2245/2460	2478/2589	2478/2589
Refrigerant	R-134A	R-134A	R-134A
Refrigerant Charge (ounces/grams)	32/907	32/907	32/907
Operating Temperature Range:			
Maximum (°F/°C)	131/55	131/55	131/55
Minimum (°F/°C)	-40/-40	-40/-40	-40/-40
Airflow at 0 Static Pressure:			
Internal loop 50 Hz (CFM / m ³ /hr.)	272/462	320/544	320/544
External loop 50 Hz (CFM / m ³ /hr.)	510/866	568/965	568/965
Internal loop 60 Hz (CFM / m ³ /hr.)	290/493	330/561	330/561
External loop 60 Hz (CFM / m ³ /hr.)	565/960	636/1081	636/1081
Max. Heater W (Outdoor Models)	1000	1000	N/A
ELECTRICAL DATA			
Rated Voltage	115	230	460V 1PH
Frequency (Hz)	50/60	50/60	50/60
Operating Range	+/- 10%	+/- 10%	+/- 10%
Max. Power Consumption (W at 50/60 Hz)	1828.5/2288.5	2070	1334/1380
Max. Nominal Current (A at 50/60 Hz)	15.9/19.9	9	5
Starting Current (A)	57	38	20
Agency Approvals	cUL Listed CE GOST	Others available upon request	cUR Recognized CE GOST
Power Input Description	6-ft. cord with NEMA 5-30 plug	6-ft. cord with NEMA 6-15 plug	6-ft. cord with wire leads
ENCLOSURE PROTECTION			
UL Type	Type 12, 3R, 4 standard Type 4X Stainless steel optional		
International Rating	IP56 on the internal loop; IP34 on the external loop		
CONTROLLER			
Description	Basic mechanical thermostat		
Thermostat Location	Enclosure side on all base models		
Factory Thermostat Setting (°F/°C)	80/27		
SOUND LEVEL			
At 1.5 Meters	73.3 dB(A)		
UNIT CONSTRUCTION			
Material	Galvanized sheet metal standard Stainless steel optional		
Finish	RAL 7035 light-gray, semi-textured powder-coat paint standard		
UNIT DIMENSIONS			
Height (in./mm)	43/1092		
Width (in./mm)	15.75/400		
Depth (in./mm)	10.9/279		
Weight (lb./kg)	125/57		

Air Conditioners

Performance Curves for T43 Models 10000 BTU/Hr. (2930 Watt)

T43-10X6-G150 Capacity Curves 50 Hz

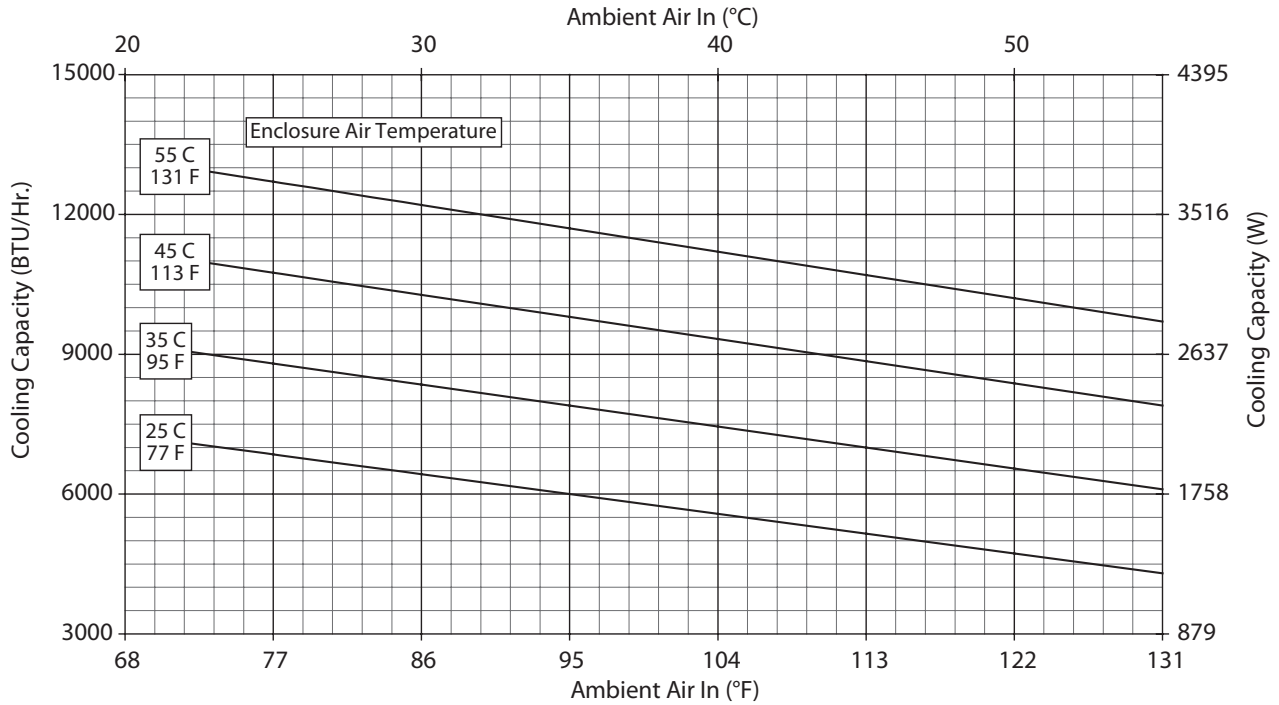

T43-10X6-G150 Capacity Curves 60 Hz

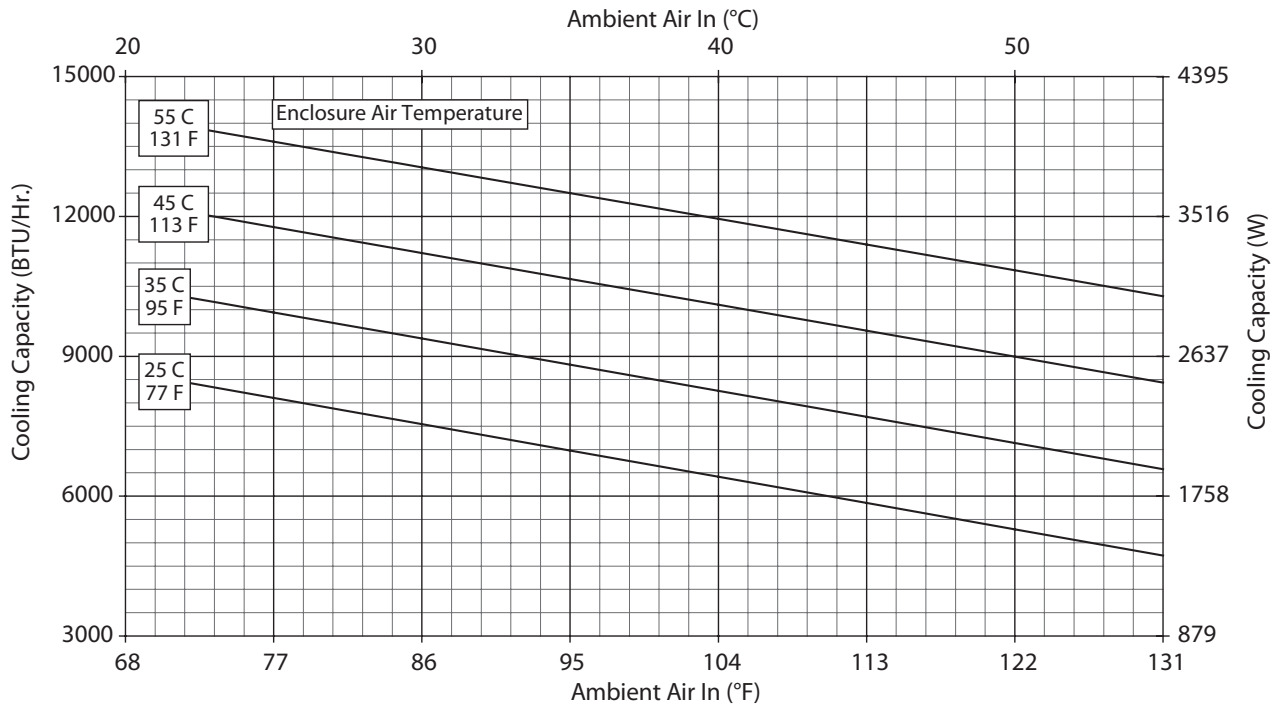

Sealed Enclosure Cooling

T43 6000-10000 Models BTU/HR. (1758 - 2930 Watt)

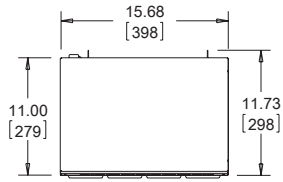

NOTE:
1. MOUNTING GASKET SUPPLIED (NOT SHOWN)
2. UNITS: in. [mm]

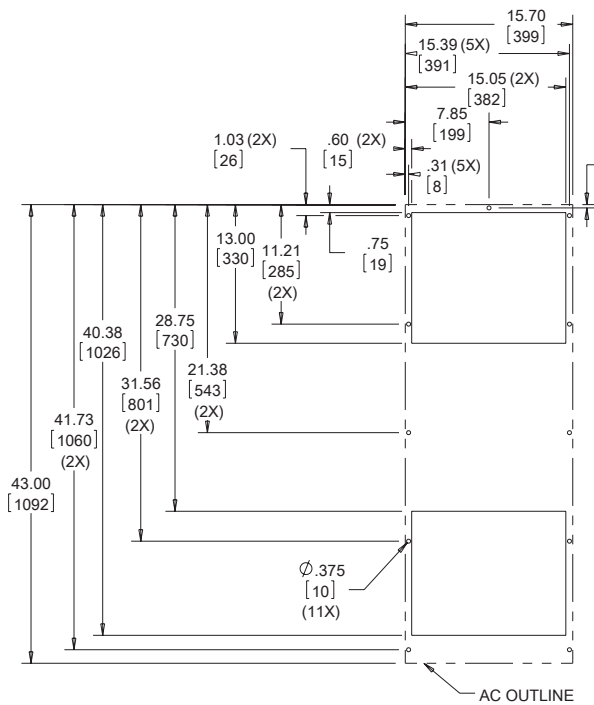
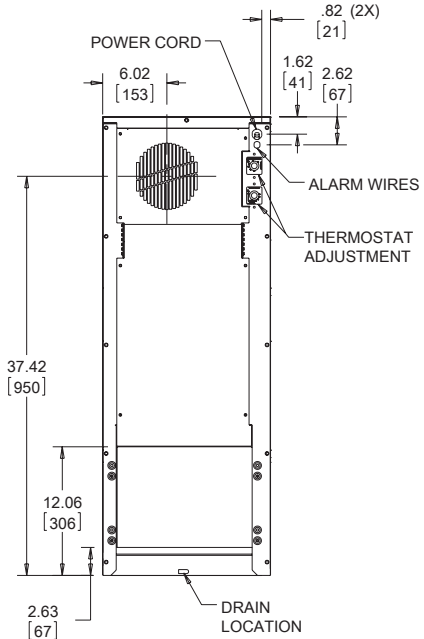
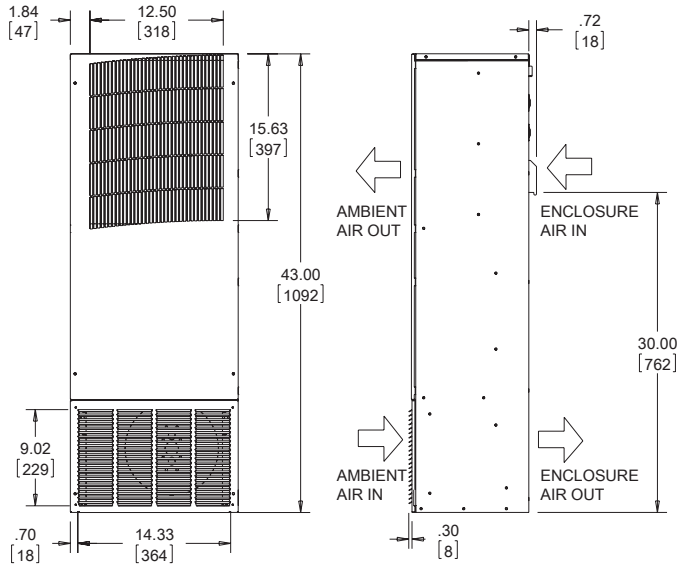

Cutout Dimensions (Externally Mounted)

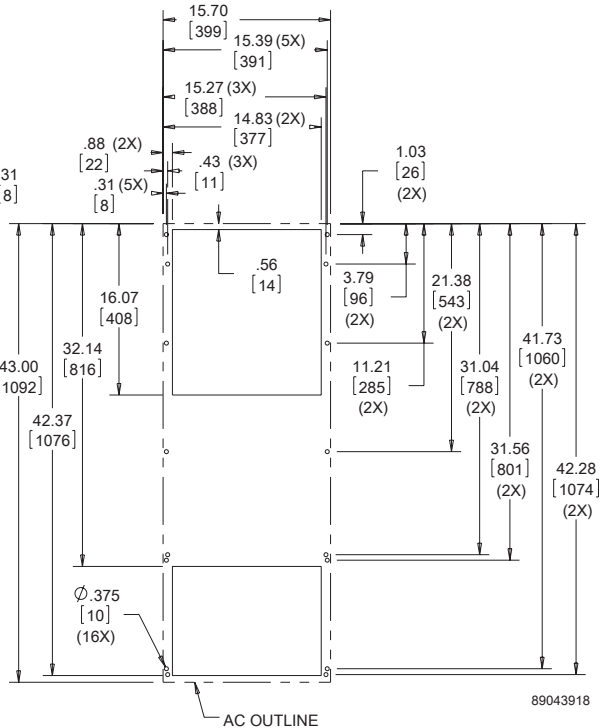

Cutout Dimensions (Internally Mounted)

89043918

Visit www.McLeanCoolingTech.com to download 2D and 3D CAD drawings into the overall design of your electronic system.

Air Conditioners

 Performance Data **T50 12000 BTU/Hr. (3516 Watt) Models**

CATALOG NUMBER		
Outdoor Model without Heat Pkg.	T501226G100	T501246G400
Outdoor Model with Heat Pkg.	T501226G150	—
Outdoor Model/SST/Corrosion/4X	T501226G125	T501246G401
Outdoor Model/SST/Corrosion/4X/Heater	T501226G156	—
COOLING PERFORMANCE		
Nominal:		
BTU/Hr.	11000/12000	11000/12000
Watts	3223/3516	3223/3516
At 131 F/131 F (55 C/55 C):		
BTU/Hr. (50/60 Hz)	10030/12000	10030/12000
W (50/60 Hz)	2939/3516	2939/3516
At 95 F/95 F (35 C/35 C):		
BTU/Hr. (50 /60 Hz)	9300/10050	9300/10050
W (50/60 Hz)	2725/2945	2725/2945
Refrigerant	R-134A	R-134A
Refrigerant Charge (ounces/grams)	46/1300	46/1300
Operating Temperature Range:		
Maximum (°F/°C)	131/55	131/55
Minimum (°F/°C)	-40/-40	-40/-40
Airflow at 0 Static Pressure:		
Internal loop 50 Hz (CFM / m ³ /hr.)	300/510	300/510
External loop 50 Hz (CFM / m ³ /hr.)	520/883	520/883
Internal loop 60 Hz (CFM / m ³ /hr.)	368/626	368/626
External loop 60 Hz (CFM / m ³ /hr.)	625/1062	625/1062
Max. Heater W (Outdoor Models)	1500	1500
ELECTRICAL DATA		
Rated Voltage	220/230	460V 1PH
Frequency (Hz)	50/60	50/60
Operating Range	+/- 10%	+/- 10%
Max. Power Consumption (W at 50/60 Hz)	1804/2139	2070/2346
Max. Nominal Current (A at 50/60 Hz)	8.2/9.3	4.5/5.1
Starting Current (A)	38	20
Agency Approvals	cUL Listed CE GOST	cUR Recognized CE GOST
Power Input Description	6-ft. cord with NEMA 6-15 plug	6-ft. cord with wire leads
ENCLOSURE PROTECTION		
UL Type	Type 12, 3R, 4 standard Type 4X Stainless steel optional	
CONTROLLER		
Description	Basic mechanical thermostat	
Thermostat Location	Enclosure side on all base models	
Factory Thermostat Setting (°F/°C)	80/27	
SOUND LEVEL		
At 1.5 Meters	68 dB(A)	
UNIT CONSTRUCTION		
Material	Galvanized sheet metal standard Stainless steel optional	
Finish	RAL 7035 light-gray, semi-textured powder-coat paint standard	
UNIT DIMENSIONS		
Height (in./mm)	50/1270	
Width (in./mm)	19/483	
Depth (in./mm)	11.05/281	
Weight (lb./kg)	164/75	

Performance Curves for T50 Models 12000 BTU/Hr. (3516 Watt)

T50-12x6-GXXX Capacity Curves 50 Hz

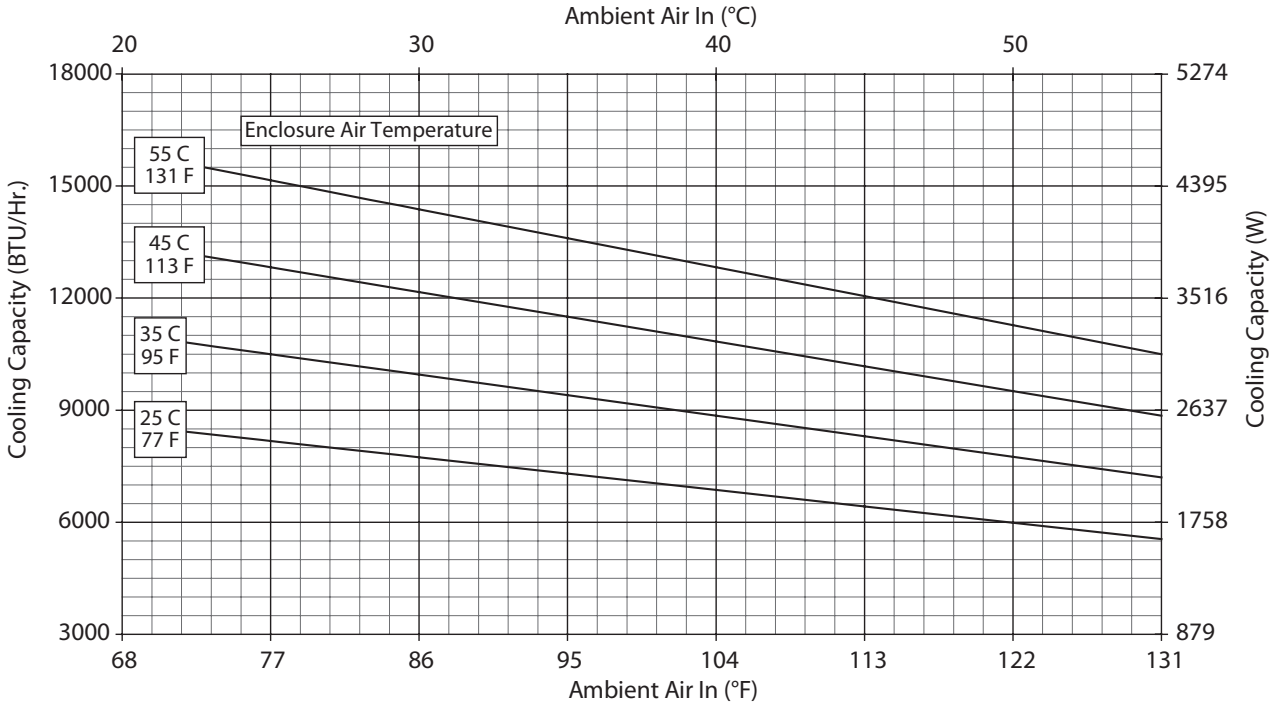

T50-12x6-GXXX Capacity Curves 60 Hz

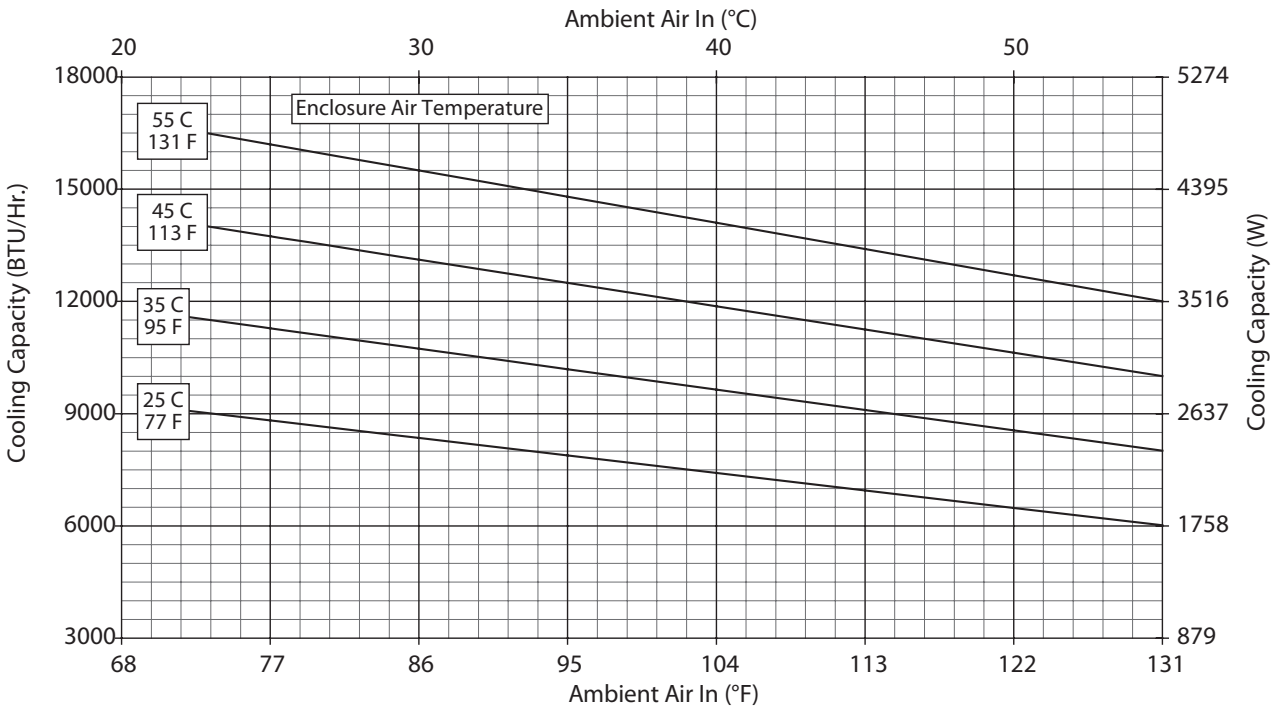

Air Conditioners

T50 Models 12000 BTU/Hr. (3516 Watt)

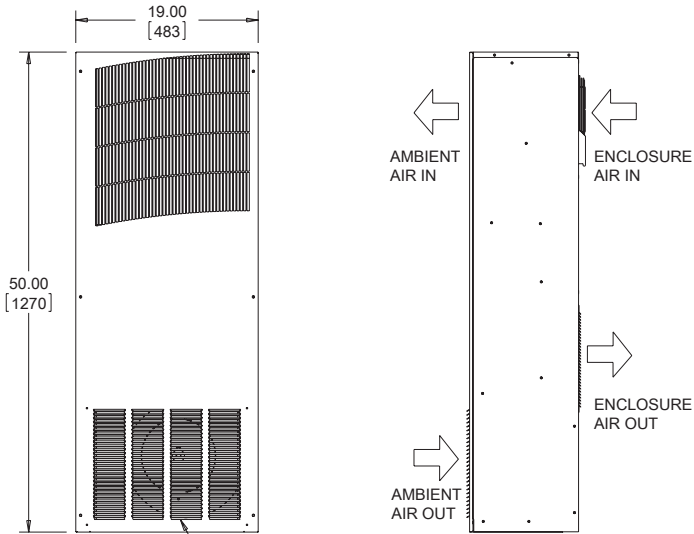

CLEANABLE, REUSABLE, ALUMINUM INLET FILTER BEHIND REMOVABLE LOUVERS

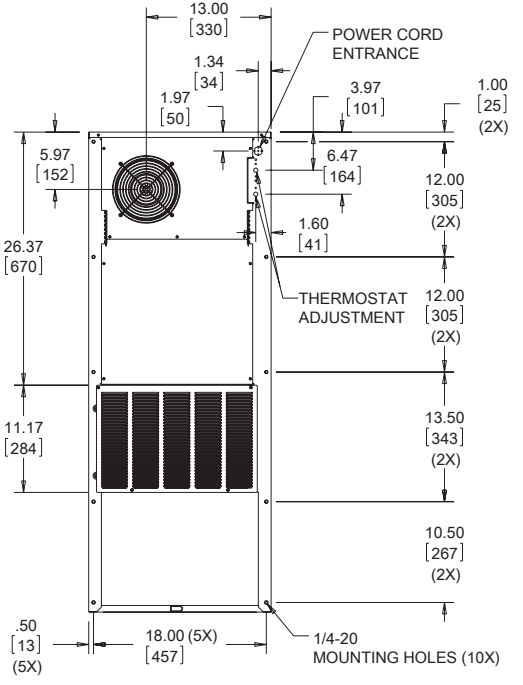
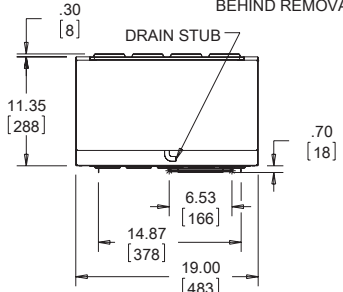

NOTE:
1. MOUNTING GASKET SUPPLIED (NOT SHOWN)
2. UNITS: in. [mm]

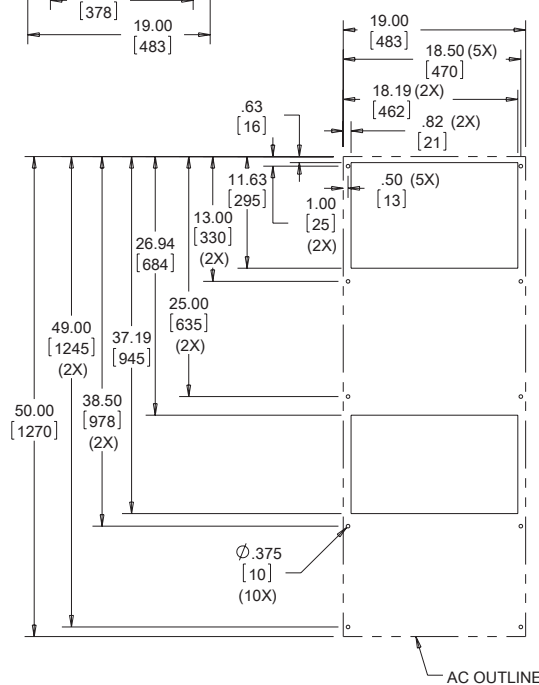

Cutout Dimensions (Externally Mounted)

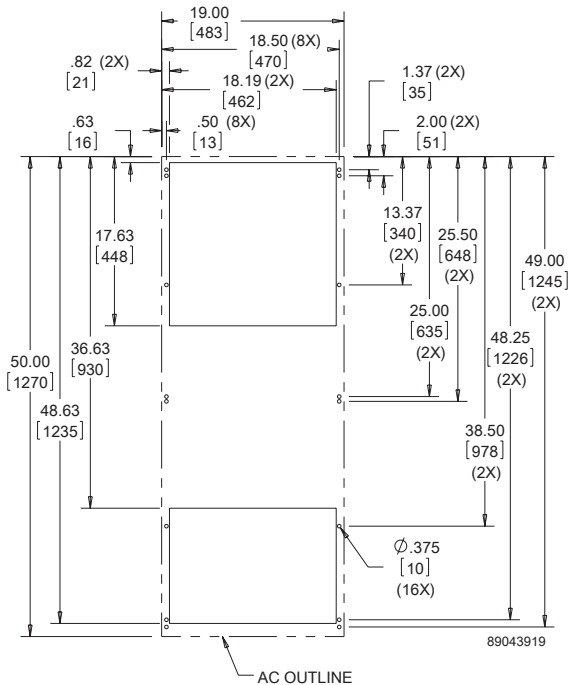

Cutout Dimensions (Internally Mounted)

Visit www.McLeanCoolingTech.com to download 2D and 3D CAD drawings into the overall design of your electronic system.

Sealed Enclosure Cooling

Performance Data **T53 19000 BTU/Hr. (5567 Watt) Models**

CATALOG NUMBER		
Outdoor Model without Heat Pkg.	T531926G100	T531946G400
Outdoor Model with Heat Pkg.	T531926G150	—
Outdoor Model/SST/Corrosion/4X	T531926G109	—
Outdoor Model/SST/Corrosion/4X/Heater	—	—
COOLING PERFORMANCE		
Nominal:		
BTU/Hr.	16800/19000	16800/19000
Watts	4922/5567	4922/5567
At 131 F/131 F (55 C/55 C):		
BTU/Hr. (50/60 Hz)	16854/19081	4939/5592
W (50/60 Hz)	4939/5592	4939/5592
At 95 F/95 F (35 C/35 C):		
BTU/Hr. (50 /60 Hz)	15240/19815	15240/19815
W (50/60 Hz)	4466/5807	4466/5807
Refrigerant	410A	410A
Refrigerant Charge (ounces/grams)	40/1132	40/1132
Operating Temperature Range:		
Maximum (°F/°C)	131/55	131/55
Minimum (°F/°C)	-40/-40	-40/-40
Airflow at 0 Static Pressure:		
Internal loop 50 Hz (CFM / m ³ /hr.)	449/763	449/763
External loop 50 Hz (CFM / m ³ /hr.)	1204/2046	1204/2046
Internal loop 60 Hz (CFM / m ³ /hr.)	519/882	519/882
External loop 60 Hz (CFM / m ³ /hr.)	1300/2209	1300/2209
Max. Heater W (Outdoor Models)	3000	
ELECTRICAL DATA		
Rated Voltage	230	460V 1PH
Frequency (Hz)	50/60	50/60
Operating Range	+/- 10%	+/- 10%
Max. Power Consumption (W at 50/60 Hz)	3979/4669	4370/5152
Max. Nominal Current (A at 50/60 Hz)	17.3/20.3	9.5/11.2
Starting Current (A)	54	28
Agency Approvals	cUL Listed CE GOST	cUR Recognized CE GOST
Power Input Description		Terminal block
ENCLOSURE PROTECTION		
UL Type		Type 12, 3R, 4 standard Type 4X Stainless steel optional
CONTROLLER		
Description		Basic mechanical thermostat
Thermostat Location		Enclosure side on all base models
Factory Thermostat Setting (°F/°C)		80/27
SOUND LEVEL		
At 1.5 Meters		76 dB(A)
UNIT CONSTRUCTION		
Material		Galvanized sheet metal standard Stainless steel optional
Finish		RAL 7035 light-gray, semi-textured powder-coat paint standard
UNIT DIMENSIONS		
Height (in./mm)		53.0/1346.2
Width (in./mm)		21.0/533.4
Depth (in./mm)		13.0/330.2
Weight (lb./kg)	197/90	237/108

Air Conditioners

Performance Curves for T53 Models 19000 BTU/Hr. (5567 Watt)

T53-19x6-GXXX Capacity Curve 50 Hz

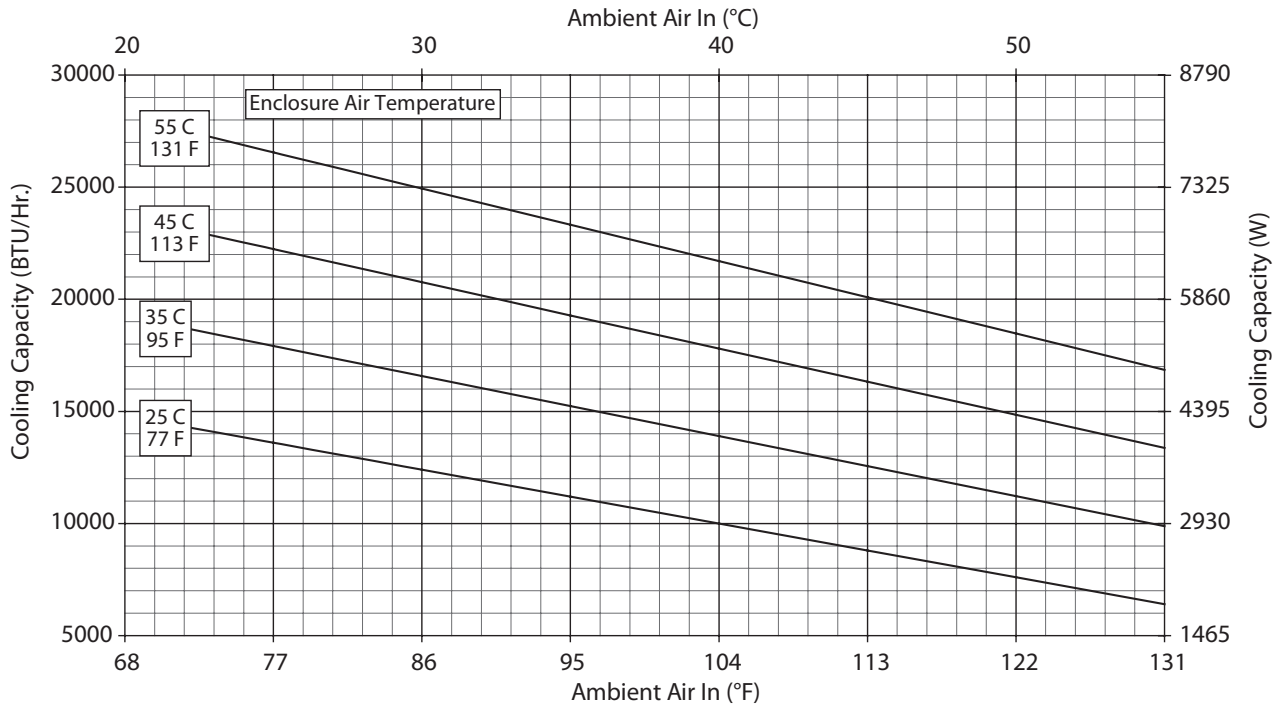

T53-19x6-GXXX Capacity Curve 60 Hz

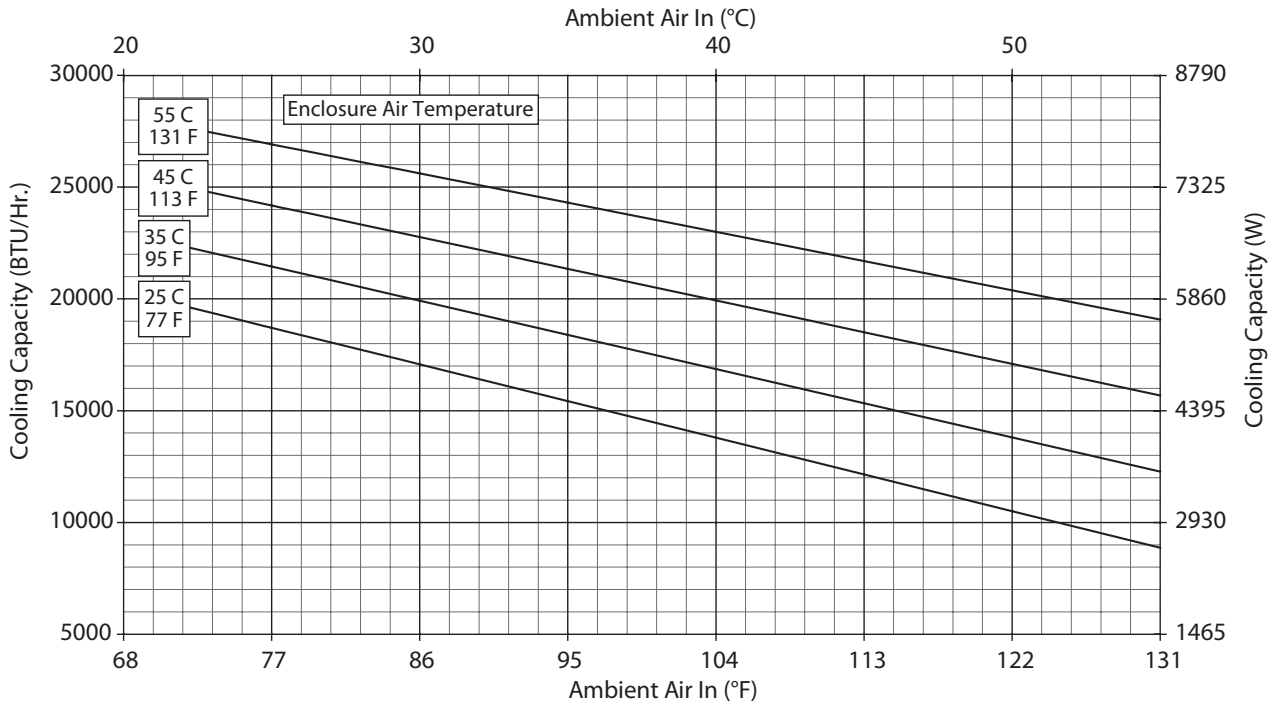

Sealed Enclosure Cooling

T53 Models 19000 BTU/Hr. (5567 Watt)

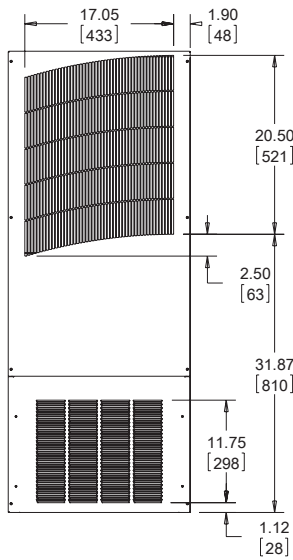
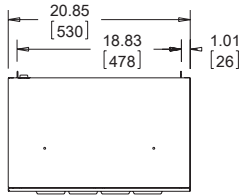

NOTE:
 1. MOUNTING GASKET SUPPLIED (NOT SHOWN)
 2. UNITS: in. [mm]

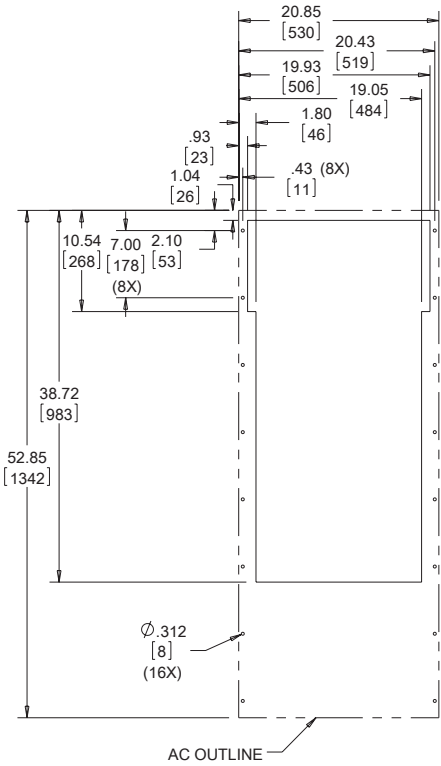
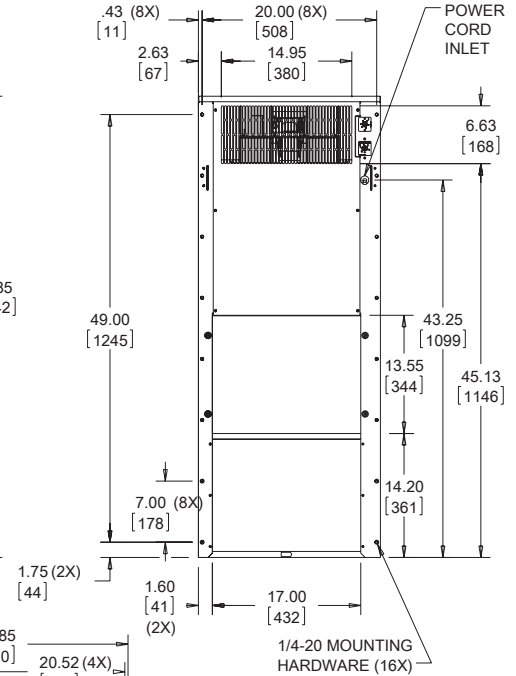
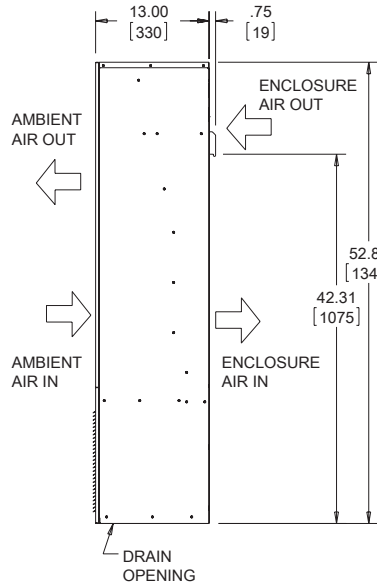

Cutout Dimensions (Externally Mounted)

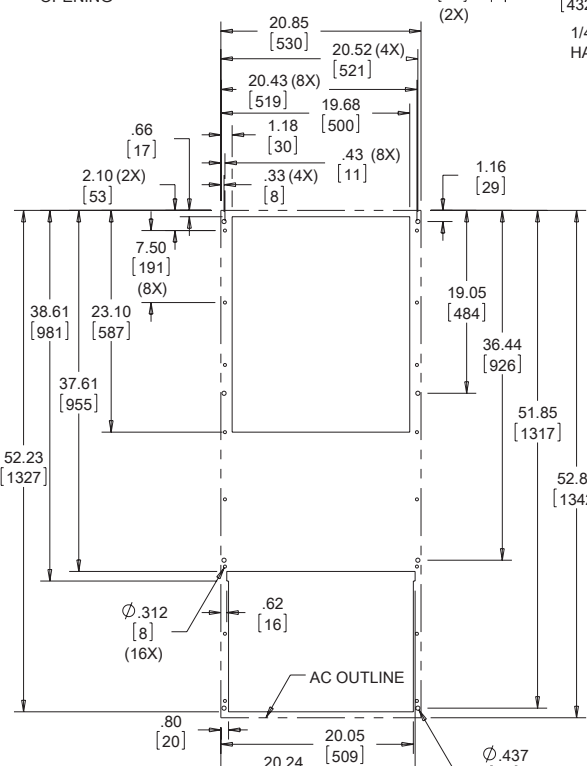

Cutout Dimensions (Internally Mounted)

89043920

Visit www.McLeanCoolingTech.com to download 2D and 3D CAD drawings into the overall design of your electronic system.